

K-Series Speed Converter (05-06 to 02-04)



Information

Congratulations on purchasing the Hybrid Racing Vehicle Speed Converter. This converter was designed specifically to convert the Vehicle Speed Signal from a 05-06 K-series transmission, to the signal found on 02-04 K-series transmissions. For K-swapped cars, this will allow for a fully functional speedometer and VTEC engagement.

Calibration

Because this converter was designed specifically for this application, no calibration is necessary.

Wiring Diagram

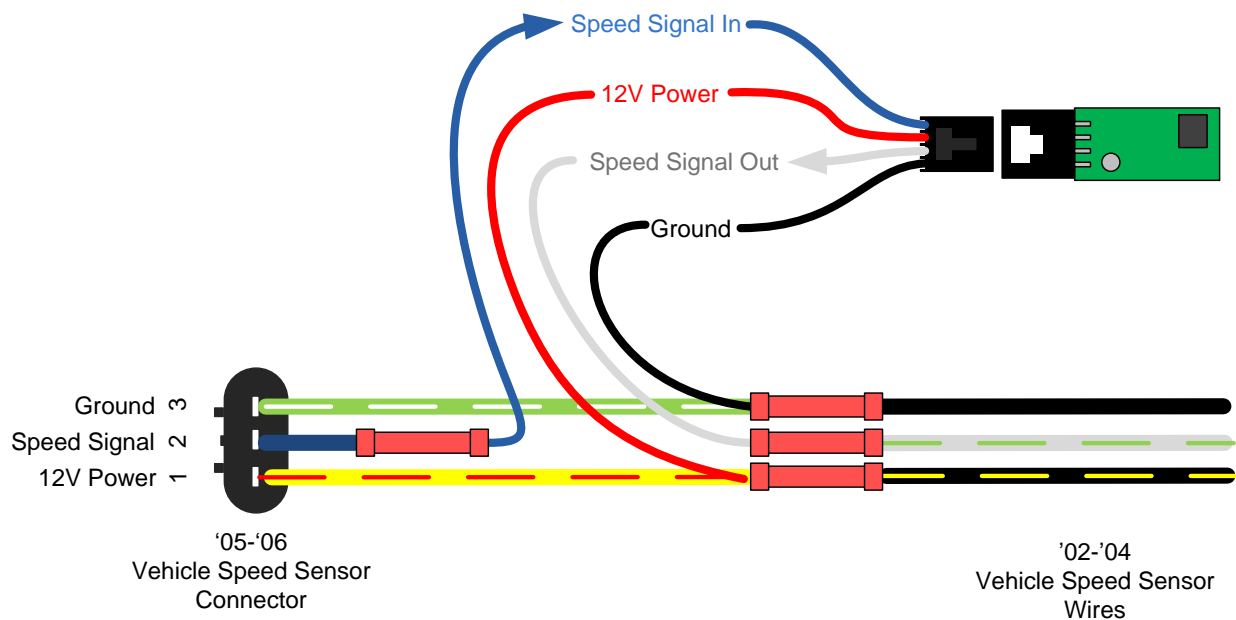

K-Series Speed Converter (05-06 to 02-04)

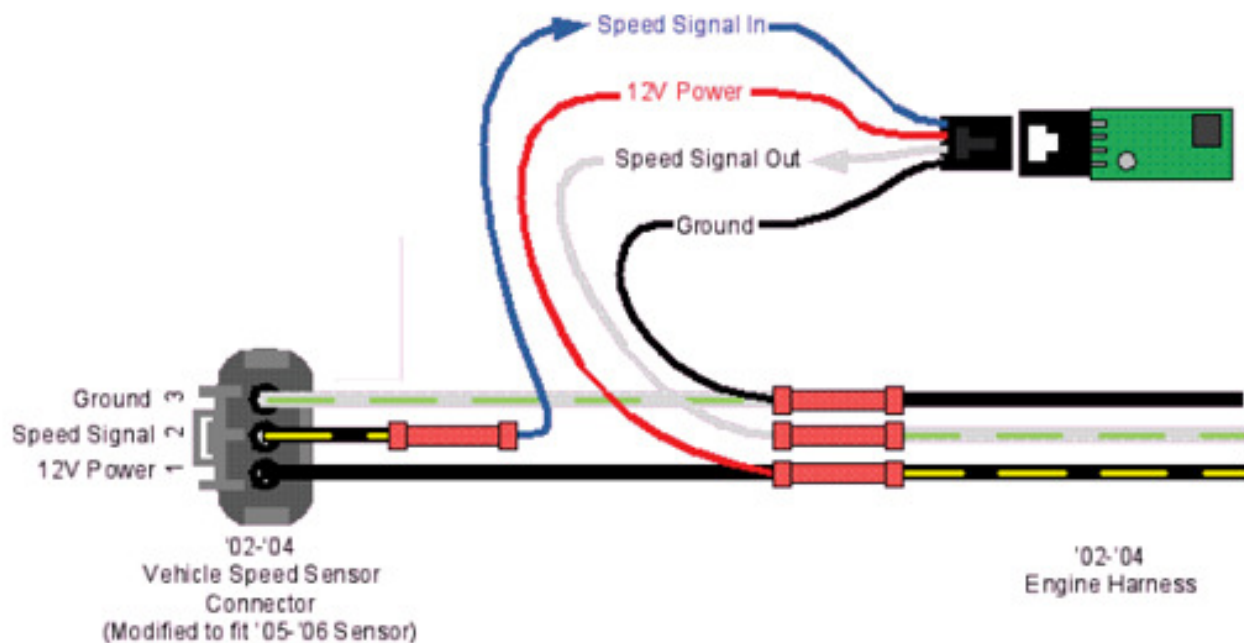

K-Series Speed Converter (05-06 to 02-04)



Connector Terminal Views

103. Output Shaft (Countershaft) Speed Sensor (A/T; '05-'06: M/T)

- Black
- Transmission housing
- On engine wire harness



- 1 YEL/RED (Reference voltage (VCC1))
- 2 BLU (Sensor output (NC))
- 3 '02-'04: BRN/YEL (G101)
'05-'06: GRN/WHT (Circuit Z27)

Connector Terminal Views

128. VSS ('02-'04: M/T)

- Gray
- Transmission housing
- On engine wire harness



- 1 BLK (G101)
- 2 BLK/YEL (Fuse 4 – Under-dash)
- 3 WHT/GRN (Circuit E93)